

P.C.B Layout
(Copper-sided view)

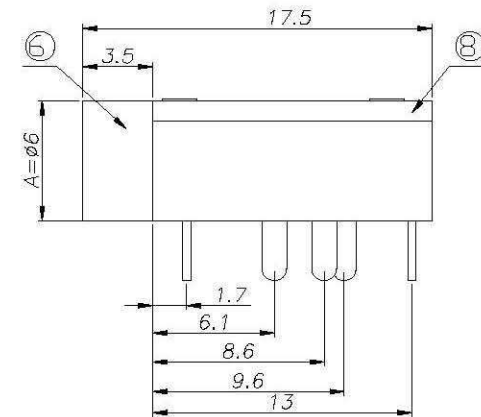

SPECIFICATION:

1. Rating Value: DC12V 1A
2. Contact Resistance: 30m
3. Insulation Resistance: 100M
4. Withstand Voltage:
AC500V(50-60Hz) for 1 minute.
5. Life Test: 5,000 Cycles
6. Operating force: 0.3~3.0kgf.

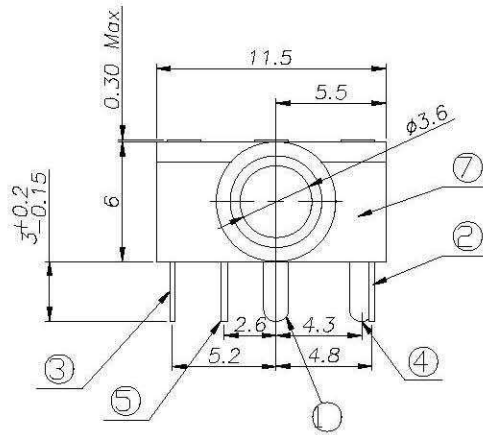
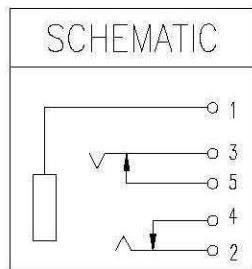

⑧	Cover	1	PC	
⑦	Housing	1	PBT	Black
⑥	AXIS SUPPORT	1	H59	Ni PLATING
⑤	TERMINAL	1	C2680	Ag PLATING
④	TERMINAL	1	C2680	Ag PLATING
③	RING SPRING	1	C5191	Ag PLATING
②	TIP SPRING	1	C5191	Ag PLATING
①	EARTH SPRING	1	C2680	Ag PLATING
NO.	DESCRIPTION	QTY	MATERIAL	REMARK

MONACOR
INTERNATIONAL

COMPUTER NO.			UNIT	SCALE	PART NAME	
			mm	2:1	PG-235J	
APPD.	CKD.	DWG.	DATE	TOLERANCE	PART NO.	REV.
		DAVID	109/03/17	±0.3		A